

To ensure that your installation proceeds smoothly,  
please read this instructions carefully before you begin.

*American Standard*

FFAS9061-093500BC0  
CYGNET TWIN SHOWER RND 3F

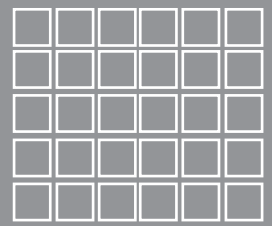
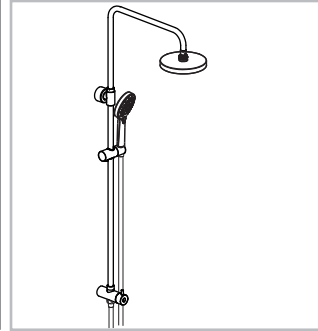

Installation &  
Operation Instruction

## Dimension

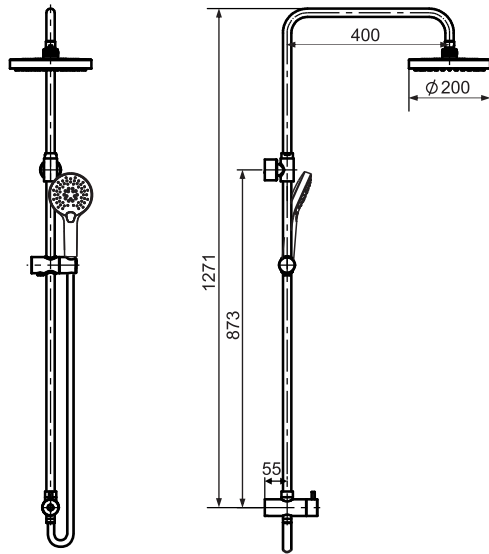

Unit: mm

## Installation

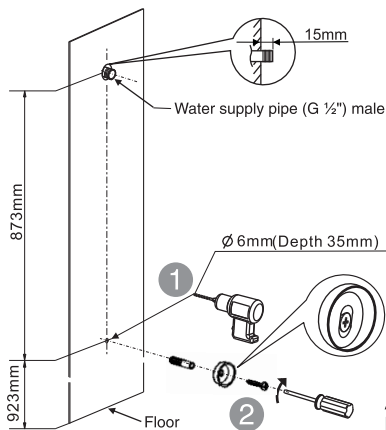

Drill hole according to the dimension.  
Anchor into the wall, then secure the  
base plate to the wall by using screw.

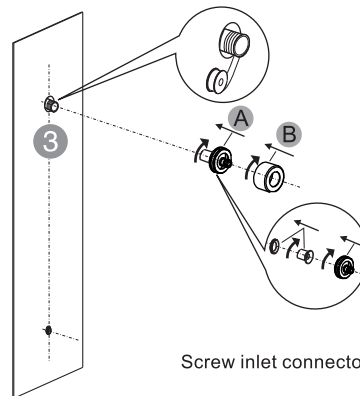

Screw inlet connector to the water supply pipe.

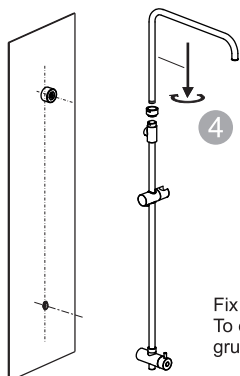

Fix the bent tube to the upper bracket as per diagram 4.  
To ensure upper bracket is positioned correctly  
the grub screw must be positioned underneath.

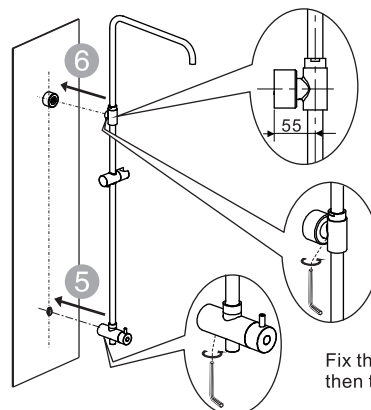

Fix the shower body to the shower rail,  
then tighten it with the In-hex wrench.

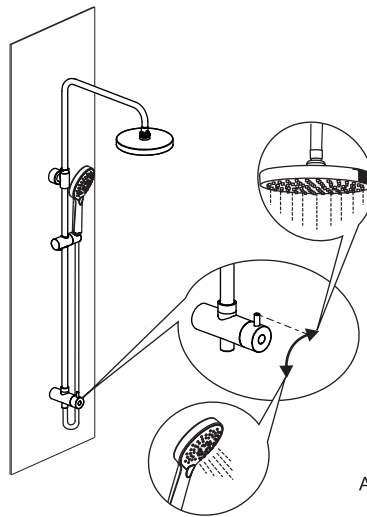
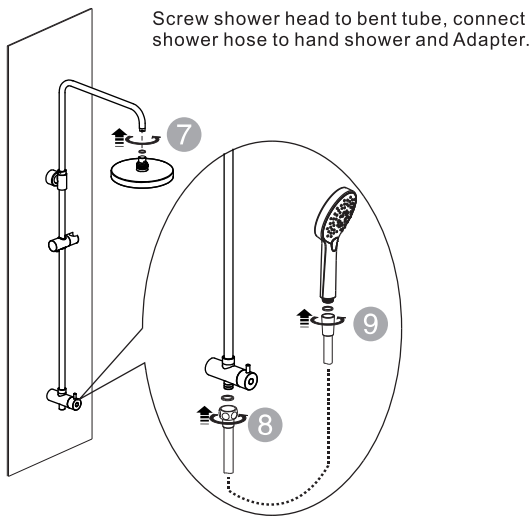

Apply pressure and check for leaks.

## Parts List

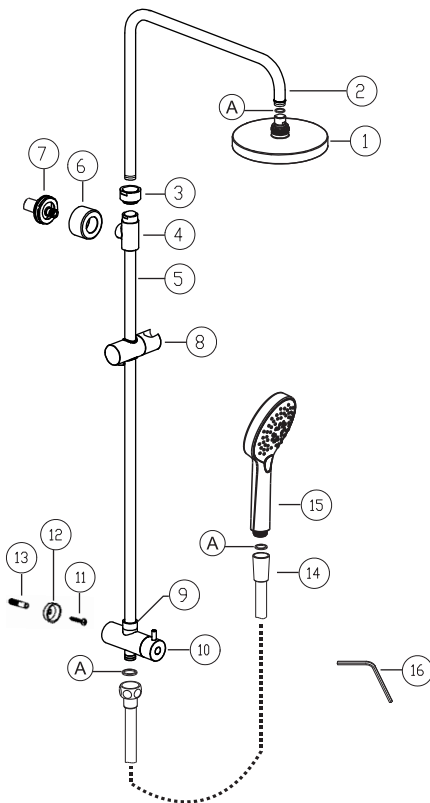

No.	Part Name	Q'ty
1	Head shower	1
2	Rail tube	1
3	Nut	1
4	Fixed sleeve	1
5	Pipe	1
6	Bracket	1
7	Bracket base	1
8	Slider	1
9	Nut	1
10	Diverter Valve	1
11	Screw	1
12	Fixing Ring	1
13	Anchor	1
14	Hose	1
15	Hand shower	1
16	L-wrench	1
A	Washer	3

## Notice

- \* Remove all impurity in pipes before beginning to avoid clogging. Connect faucet pipes correctly.
- \* Check installation distances in the Dimension diagram to ensure correct installation.

### Conditions for use

- \* Pressure limiting value must be installed limited to 500Kpa
- \* Best performance we recommend 150 to 500Kpa
- \* Hot & cold water inlet pressure should be equal
- \* Recommended maximum water temperature 65C

**AUS**

Reece Australia Pty Ltd  
118 Burwood Hwy  
Burwood VIC 3125

Tel.: 1800 080 055  
Email: [customercare@reece.com.au](mailto:customercare@reece.com.au)



**NZ**

Robertson  
25 Vestey Drive  
Mt Wellington, Auckland

Tel.: +64 9 5730490  
Email: [sales@robertson.co.nz](mailto:sales@robertson.co.nz)