

Zen SS316L Basin Mixer

Nero

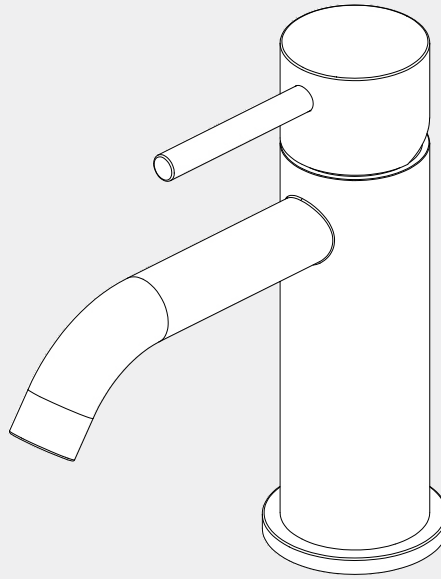

Lead Free



Versions:202405



Drawing

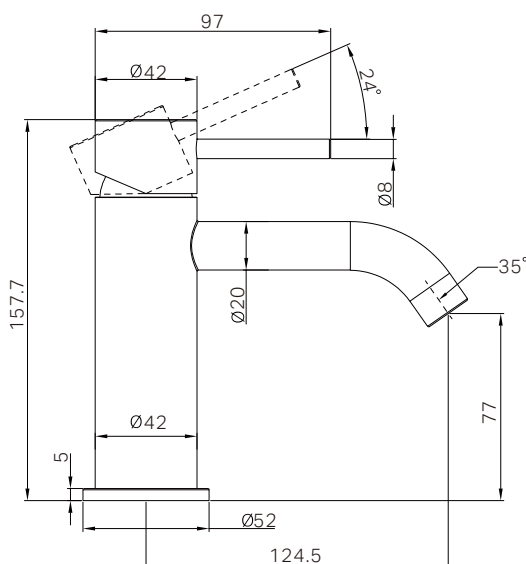

Specifications

Watermark License

WM-060073





Temperature Rating

Min 1°C - Max 75°C

Pressure Rating

Min 150kpa - Max 500kpa

Finish & SKU

- | | |
|---|---|
|  Brushed Bronze
NR162201BZ |  Graphite
NR162201GR |
|  Brushed Gold
NR162201BG |  Brushed Nickel
NR162201BN |

Packaging Includes

- 1x Basin Mixer
- 1x Installation Kit
- 1x Aerator Spanner

*Dimensions are nominal measurements only.

Installation Instruction

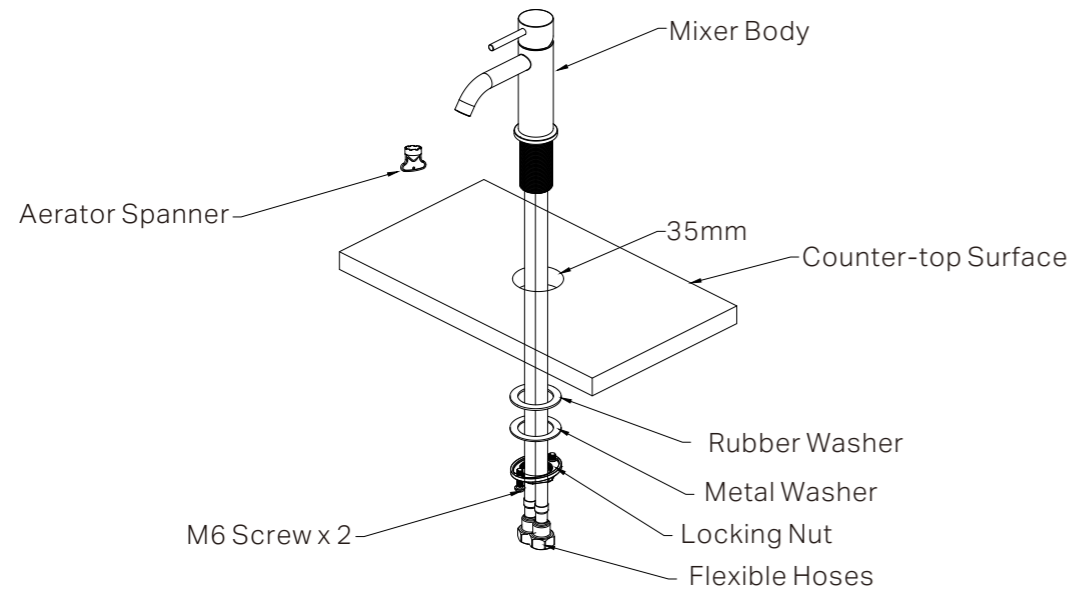

GENERAL INSTRUCTIONS:

- This product must be installed by a licensed plumber. Ensure that your plumbing installation conforms to the Australian/New Zealand Standard AS/NZS 3500.
- All pipework must be thoroughly flushed prior to the installation of the mixer. In-line filters must be fitted on both hot and cold supplies to prevent foreign particles from damaging the ceramic cartridge.
- All outlets used primarily for personal hygiene must deliver water at a safe temperature in accordance with regional regulations.

NOTE:

- Do not hydrostatic test the installation with this mixer installed. Damage to the ceramic cartridge may occur.
- Do not remove the ceramic cartridge from the mixer when installing.
- After installation, all connections must be checked for leaks.
- This mixer is not recommended for use in uncontrolled heating systems such as wet-backs or solar heating units unless a suitable tempering valve is fitted.
- If limited water flow is experienced, locate aerator and filter washers and clean away foreign material as required.
- It is the responsibility of the plumber to ensure a waterproof seal is achieved between the product and mounting surface. If in doubt about the quality of the seal, remove the product and reinstall.

MAINTENANCE AND CARE:

- Regularly check the mixer and connections for signs of wear or leaks.
- Clean the tap with mild soapy water to maintain its appearance, avoiding harsh chemicals and abrasive materials that may damage the finish.

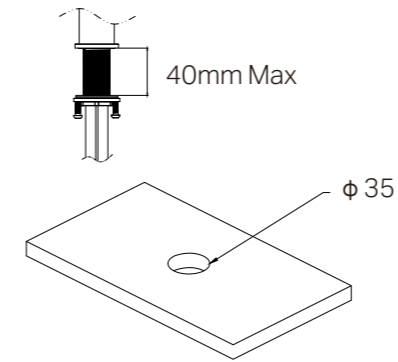

1. Pre-drill or create a hole with a diameter of 35mm at the proper location. Please note that the thickness of the surface should be between 3mm-40mm.

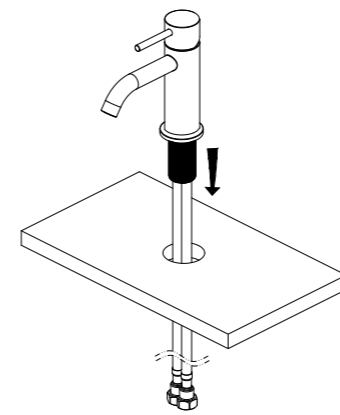

2. Place the mixer body and pass the Pex hoses through the hole in the counter-top. Ensuring the O-RING sits within the bottom groove of the base plate to prevent water leakage through the cabinet.

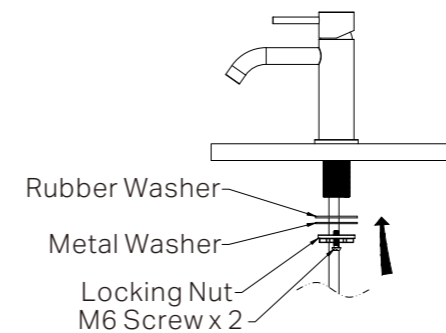

3. Install the rubber and metal washers, tighten the locking nut securely with the two M6 screws to ensure the mixer is firmly attached to the counter-top. Avoid over tightening to prevent damage to the components.

4. Connect the Pex Hose to the corresponding hot and cold water supply valves. Tighten the Female cone nuts by hand(According to Pex hose instruction). Ensuring they are secure yet not overtightened to avoid thread damage.

5. Check all connections for leaks. If any fittings are leaking, shut off the water as necessary to stop the leaks. Contact the supplier for warranty claim. Refer to warranty page.

FINAL INSPECTION:

- Ensure the tap operates smoothly and that there are no leaks at the connections.
- Clean the area and the newly installed tap with a soft cloth to remove any installation residues.

Nero

