

Installation Instructions and User Guide

tastic

EASY DUCT

Model: 11511 Easy Duct Triumph

Model: 11532 Easy Duct Mirage

Model: 12511 Easy Duct Sensation

Electrical Rating: 230~240 V. 50 Hz.

Welcome

Thank you for buying this IXL Tastic. Even if you have used a Tastic before, there are very good reasons to read this user guide before using this one:

- You and your family, property and home will be safe from harm.
- You will learn how this appliance may differ from others.
- By using the Tastic fully and properly, you will get maximum life and value from it.
- Our warranty depends on you using the Tastic according to this user guide.

It will only take you a few minutes, so please read on!

Contents

Easy Duct Tastic Range	Pg 3
Safety	Pg 4-5
How it Works	Pg 5
Ventilation Requirements	Pg 6
Clearances	Pg 6
Overview	Pg 7
Electrical Requirements	Pg 7
Wiring Diagrams	Pg 8
Wiring Aust & NZ	Pg 9
Installation	Pg 10-13
Replacement Lamps	Pg 13
Cleaning & Maintenance	Pg 14
FAQ's	Pg 14-15
Warranty	Pg 16-17
Warranty Registration	Pg 18

Tastic®

Easy Duct Tastic Range



Model: 11511 Triumph

11511 Easy Duct Triumph

2 x 275 W Heat, Vent & Light

10 W R80 LED Centre Globe

Cutout Template Supplied

170 mm Ducted Blower, 210m³/hr or 58l/s



Models: 11532 Mirage

11532 Easy Duct Mirage

2 x 275 W Heat, Vent & Light

10 W R80 LED Centre Globe

Cutout Template Supplied

170 mm Ducted Blower, 210m³/hr or 58l/s



Model: 12511 Sensation

12511 Easy Duct Sensation

4 x 275 W Heat, Vent & Light

10 W R80 LED Centre Globe

Half Heat Function

Cutout 330 mm x 330 mm

170 mm Ducted Blower, 223m³/hr or 62l/s

Read through these instructions completely before commencing installation.



Do not allow insulation material to rest against the sides or top of the Tastic unit when installed. This Tastic must not be installed where there is a possibility of water splashing on to the lamps. There is no IP rating on any IXL Tastic.

NOTE: This product must be installed by a qualified installer.

The infra-red lamps heat by direct radiation rather than by heating the air in the room, so the Tastic should be located directly over where drying off occurs.

Locate the Tastic in accordance with the requirements of the current Australian/New Zealand Wiring Rules AS/NZS 3000 relating to damp situations, or according to applicable Wiring Rules for installations outside of Australia and New Zealand.

In some installations this may mean that no part of the Tastic may be located directly above any part of a bath or shower recess or enclosure.

For unenclosed showers refer to Wiring Rules conditions.

Switches and other controls must not be located where they can be touched by a person in the bath or shower.

NOTE: Tastic products must only be installed horizontally in ceiling.

- Do not look directly into heat lamps when in use.
- Tastic products are not tanning lamps.
- Make sure the lamps have cooled and power is off to the Tastic before removing lamps for replacement.
- Do not operate this appliance without the fascia in position.
- This appliance is not intended for use by persons (including children) with reduced physical, sensory or mental capabilities, or lack of experience and knowledge, unless they have been given supervision or instruction concerning use of the appliance by a person responsible for their safety.
- Young children should be supervised to ensure they do not play with the appliance.
- This appliance must be mounted with the lowest point at least 2.1 metres from the floor.
- This appliance must not be mounted immediately below a socket outlet.
- Regulations concerning the discharge of air have to be fulfilled.

WARNING: Curtains or combustible material may ignite if in contact with the heater.

SAFETY FEATURES

Thermal switch:

When Easy Duct Tastic works in FAN OFF mode and the temperature inside the unit reaches 55°C, the thermal switch will switch on the fan automatically. When the temperature drops, the thermal switch will switch off the fan.

Over-temperature switch (PTCR):

When for any reason the temperature inside the unit reaches 80°C for model 12511, the PTCR will cut off power to the Easy Duct Tastic. The PTCR can be reset by turning off power to the unit at the isolating switch and allowing to cool for 10-15 minutes. The fusible resistor in models 11511 & 11532, when it reaches 93°C will cut off the power. It is non-resettable. In such a case the Service Centre should be called as this is not normal operation.

How it Works

The IXL Tastic range has been designed to exacting standards to give you many years of trouble-free operation. To ensure you get the most from your Tastic there are a few simple points to keep in mind.

HEAT LAMPS

The IXL Tastic Heat Lamps have no warm up period because the infra red lamps provide instantaneous heat, and are designed to heat you and not your bathroom - that's the efficient way infra red heat works. You'll save money and energy, with an average cost of around one cent a shower if used correctly, (based on average 5 minute drying time). Also, to get the full benefit of Tastic's infra red warmth, stand directly under the heat lamps. IXL's exclusive clear heat lamps have been designed specifically for this application, and concentrate their heat for maximum effectiveness.

Make sure you have the Tastic model that suits your bathroom ceiling height. This Tastic is manufactured to offer peak performance with bathroom ceiling heights up to 2.4 m for the Triumph 11511 and Mirage 11532, 2.7 m for Sensation 12511.

The Tastic half heat function is available on the 4 lamp models, and is another energy saver, allowing you to adjust the heat level to suit prevailing conditions or personal preference.

VENTILATION

To ensure optimum performance of the exhaust fan, it is essential that there is adequate air flow into your bathroom to help the Tastic's powerful and efficient exhaust fan to quickly remove steam while you shower. Your Tastic works by drawing steam-laden air from the room, and as with all exhaust fans it is essential that sufficient air inlet is provided. Ensure adequate inlets exist through windows, vents or under the door. Air flow path from inlet to fan should ideally pass over the steam source.

CENTRE LIGHT

The centre light in all Tastic models is designed to provide general illumination in your bathroom.

Note: For efficiency purposes, the centre light will not operate simultaneously with the heat lamps.

Ventilation Requirements

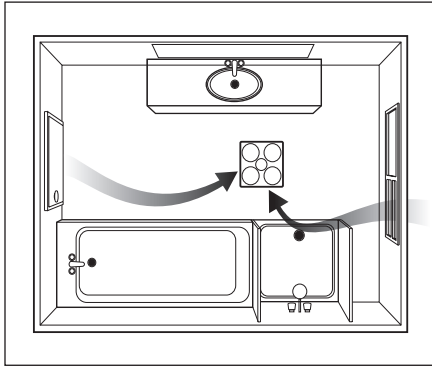

Fig. 1: Ideal placement of Tastic.
Sufficient air inlets into room are required

For maximum efficiency and fan performance there are a few key points to keep in mind when installing your Tastic.

Sufficient air inlet into room

Steam will only be removed if there is sufficient flow of air through the room. Ensure generous inlets exist through windows, vents or under the door. Air flow path from inlet to fan should ideally pass over the steam sources (see Fig. 1).

Clearances

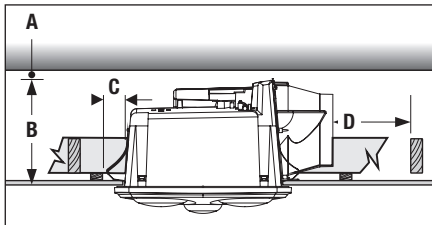

Fig. 2: Minimum clearances for installation

This appliance must be mounted so that the lowest point is at least 2.1 m above the floor. The Tastic body and ducted blower is designed to fit a ceiling cavity or between – floor space with a minimum height of 235 mm (Fig. 2). The Tastic may be installed between joists using the in built clip fasteners. Ensure the outlet of the Tastic is directed towards the outer wall. If the desired orientation of the Tastic unit directs the ducting across ceiling joist ensure that the closest ceiling joist is not within 200 mm of the Tastic outlet.

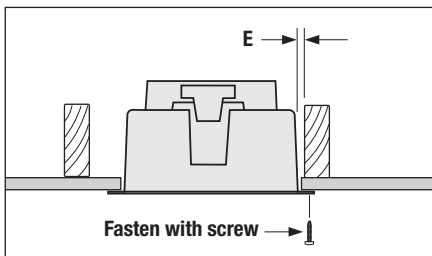

Fig. 3: Joist clearances

Figure 2

A: 15 mm min. **B**: 220 mm. **C**: 35 mm min. clearance required when using the in built clip fasteners. **D**: 200 mm min. clearance between Tastic outlet and nearest ceiling joist.

Figure 3 measurement E:

20 mm min. clearance on the two vertical sides.

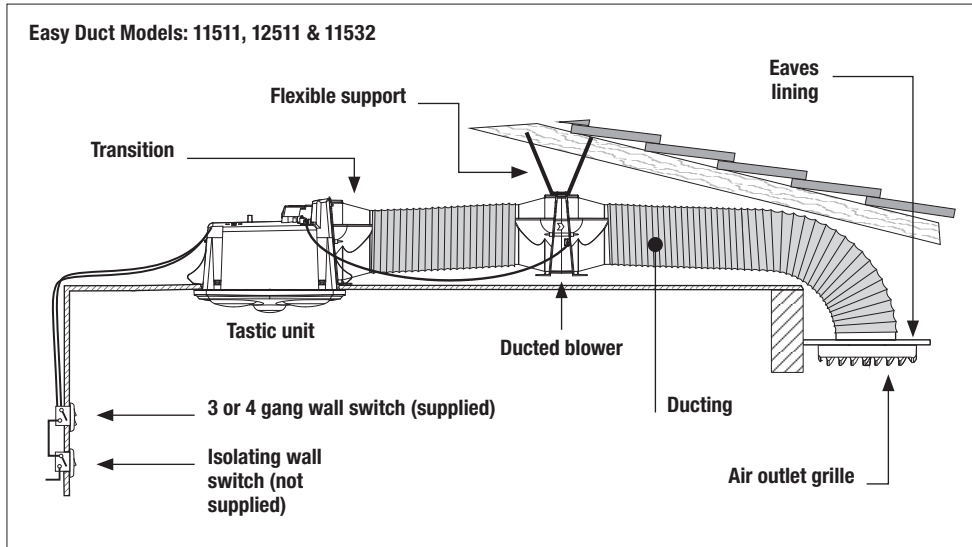

Fig. 4: Layout of Tastic Easy Duct

Electrical Requirements



Tastic units are fitted with a LED centre lamp. To ensure correct operation and to prolong the life of the LED please wire as per the following wiring diagrams for the appropriate model.

See the wiring diagrams on the following pages for supply requirements and maximum loadings for each model. Tastics may be connected to a lighting or power circuit if loading permits. These models are for wired-in installation and wiring must be carried out by a registered electrician. Switches and a wall plate are provided with the Tastic*. Do not use this product with any solid state speed control or commercial dimming device. If the supply cord is damaged, it must be replaced by IXL Home, its service agent or similarly qualified persons in order to avoid a hazard.

* Number of switches depends on your Tastic model.

* Excludes Model 11532 (Tastic Easy Ducted Mirage 3 in 1)..

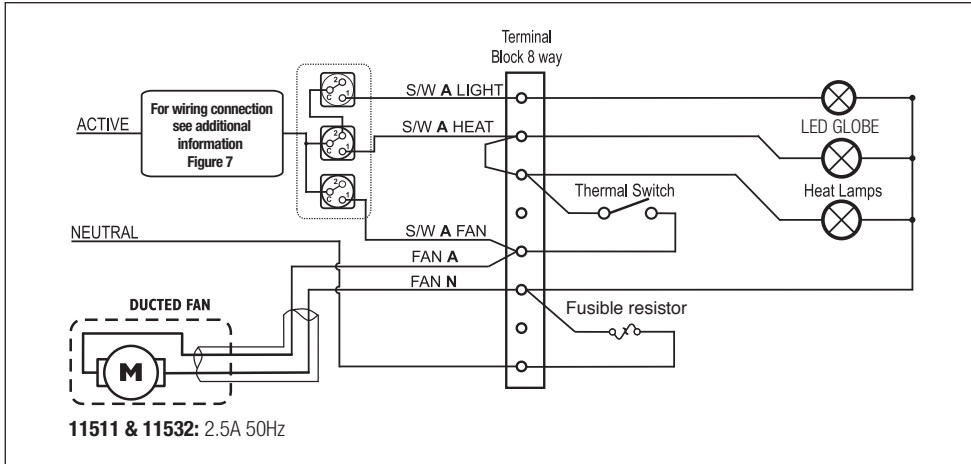

Fig. 5: Wiring diagram for model 11511 & 11532

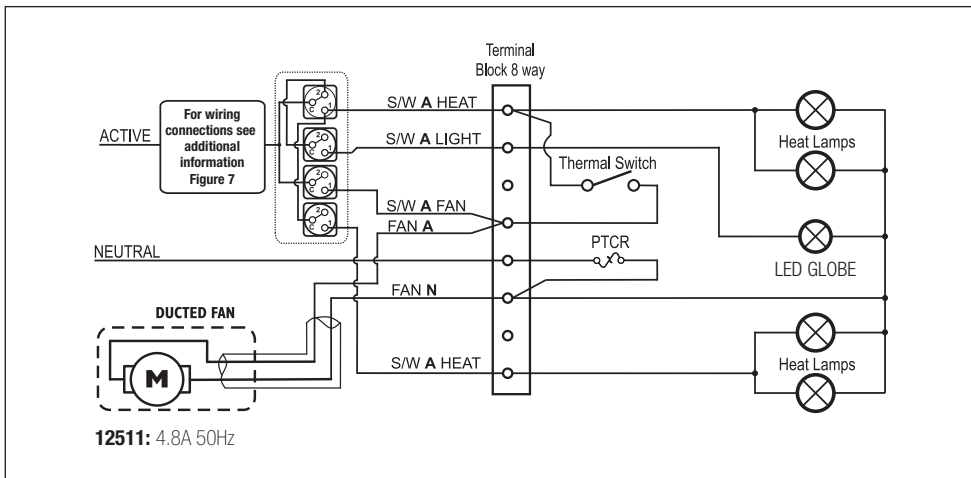

Fig. 6: Wiring diagram for model 12511

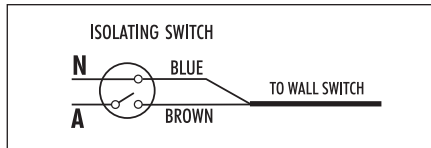

Fig. 7: Hardwired

Hardwired models 11511, 12511 & 11532: A local isolating switch (not supplied) must be incorporated in the fixed wiring to the appliance to allow disconnection of supply during maintenance. This isolating switch should be located in close proximity to the Tastic and must be installed in accordance with applicable Wiring Codes.

The Tastic may be installed between joists using the in built clip fasteners. Alternatively, the unit can be installed against a joist using two screws through notches located in the flange (Fig. 3 on page 6), provided that the clearances for the two vertical sides are maintained as per Fig. 2 on page 6.

IMPORTANT: Joists, beams and rafters shall not be cut or notched to install the appliance.

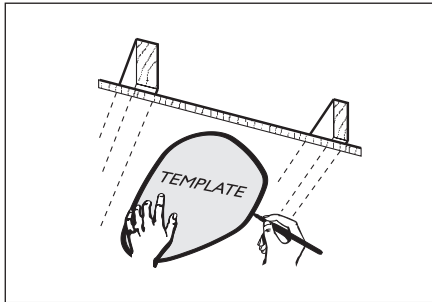

Fig. 8: Use template to mark position of Tastic

Depending on your model, the Tastic has a weight of 2 – 3.5 kg (see below). If adequate support is not available for the Tastic, it may be necessary to provide extra strengthening.

Triumph & Mirage – approx 2 kg

Sensation – approx 3.5 kg

NOTE: This product must be installed by a qualified installer. Ensure power is off to location of Tastic.

1. After determining the location of the Tastic and components according to directions, use the card included with your Tastic Carton as a template to mark out and cut an aperture in the ceiling (Fig. 8). Make sure that template is parallel to a wall.
2. Remove fascia from the body. Remove all lamps.
3. Unscrew terminal cover.

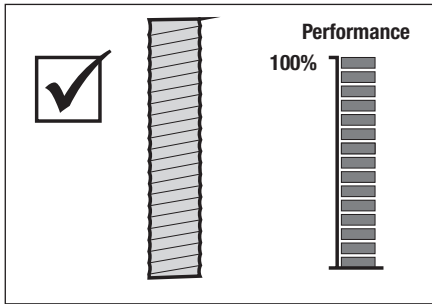

Fig. 9: Straight ducting

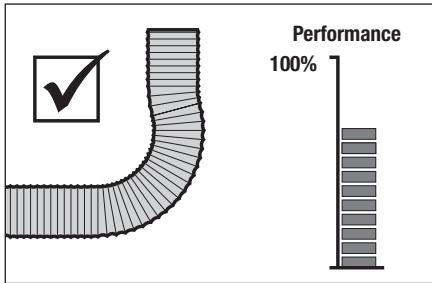

Fig. 10: Gradual bends, ducting stretched straight

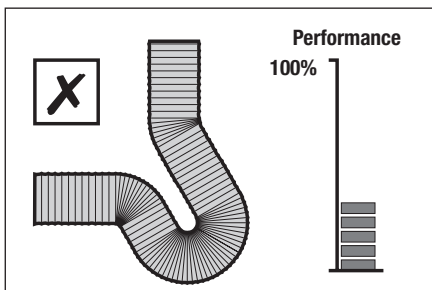

Fig. 11: Tightly compressed bends

Ducting

1. These products have been designed to suit 150 mm dia. ducting. Determine the length of ducting required ensuring that the length is as short as possible. Refer to Fig's 9 – 11 to attain optimum performance.
2. Tape a length of ducting 1 m long (max) between the blower inlet and the Transition. Tape remaining length of ducting to exit of blower.

Installing the Ducted Blower

NOTE: The transition is assembled to the main body after the main body has been snapped into place in the ceiling.

1. Feed ducting and blower through hole in ceiling. While feeding ducting into ceiling direct it towards the installation position of the outlet grille. Position blower so that the short length of ducting is stretched out and Transition piece along striped or terminated wire is sitting next to the hole as seen in Fig. 12.

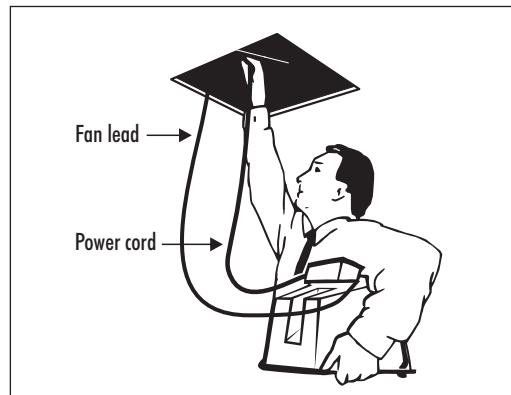

Fig. 12

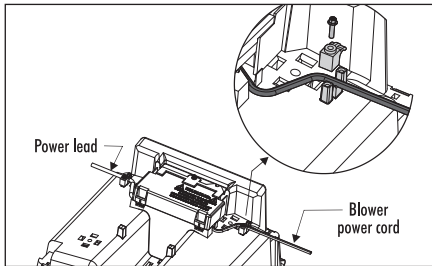

Fig. 13

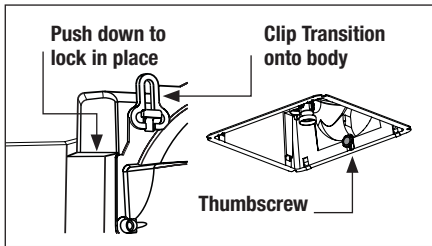

Fig. 14

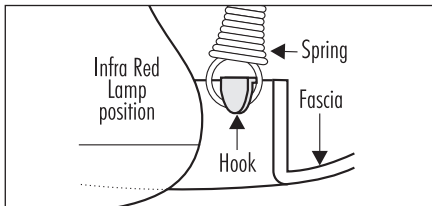

Fig. 15 – 11511, 11532

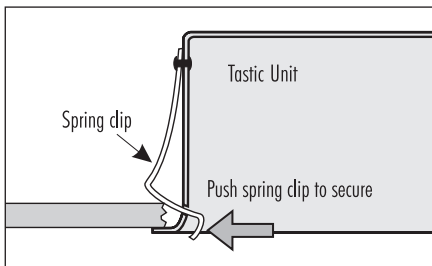

Fig. 16

2. Cut plug from end of blower power cord and strip wires 10mm. Make the necessary electrical connections i.e. connect wiring from blower assembly and wall switch to terminal block as per circuit diagram. For models 11511, 12511 and 11532 reposition terminal cover on top of the Tastic unit and then secure with screw. Fit two cord anchor clamps as per Fig. 13.
3. Push Tastic body into ceiling aperture, allowing metal springs to snap open. As the Tastic is raised into the ceiling, ensure electric cables do not rest over the Tastic.
4. Connect Transition to Tastic body and secure with thumbscrew as shown in Fig 14.

Final Assembly

1. Model 11511, 11532, remove lamps and centre globe to fit fascia into position and hook coil-spring onto fascia as per Fig. 15. Model 12511 has a snap-on fascia, however the lamps and centre globe must be fitted in these models prior to the fascia. The legs of the lamp surround must rest freely on the ceiling. A clearance of approximately 3-5 mm should exist between the ceiling and outer rim of surround.
2. Insert infra-red lamps and centre globe into socket and screw in well to give good electrical contact to ensure correct operation.
3. To secure the Tastic in position, push lower ends of springs apart (Fig 16). Ceiling board thickness should be adjusted to enable springs to be fitted without excessive force.
4. Centralise fascia and wipe surround and bulbs clean.
5. Turn on power at the isolating switch and check operation of Tastic.

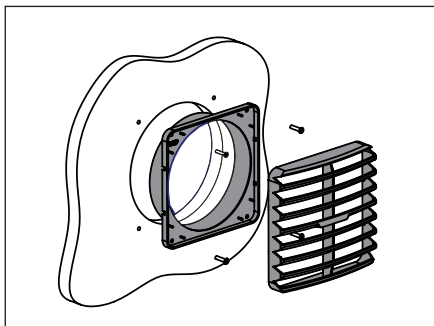

Fig. 17

Installing the Grille

1. Cut a hole 160 mm in diameter in eaves or outer wall. Feed ducting out through this hole and tape to the Grille baseplate.
2. Feed the ducting back through the hole so that the Grille base is against the eaves or outer wall.
3. Fix Grille base with four 6 G screws and snap fit the Grille louvres over the Grille base as shown in Fig. 17.

Replacement Lamps

The Sensation lamp fascia must be removed prior to replacing lamps. Ensure lamps are screwed well in after replacement to give good electrical contact.

NOTE: Replacement with any other lamps other than those listed below may cause damage to the moulding and void the warranty.

Heat Lamps

The IXL Tastic lamps have been specially developed for best performance.

275 watts max IXL Model no. 11300.

NOTE: Replace only with genuine IXL approved Hard Glass Infra-Red lamps.

Light Bulb

10 W R80 LED IXL Model no. 12281

Light bulb is not covered by manufacturer's warranty.

NOTE: 100 W maximum light bulb on all above Tastics.

WARNING: Always make sure the unit is turned off and allow all bulbs to cool before cleaning. Maintenance of the Tastic is required to ensure the quality of the product and functions are maintained.

It is recommended that the Tastic body, fascia and globes be checked and cleaned every 2 years.

To clean bulbs and lamp fascia use a damp cloth with liquid glass cleaner. Fascias are dishwasher safe.

Cleaning and maintenance will help to preserve the life-span and performance of the Tastic.

FAQ's

Service

NOTE: Do not remove the Tastic from the ceiling. Your Tastic will be serviced in your home.

If service is required, please contact customer service at IXL Home on 1300 727 421.

Frequently asked questions

Q – Will my Tastic heat my bathroom?

A – No, your Tastic is designed to provide infra red radiant heat to warm the body while drying, when standing directly underneath. It is not designed as a room heater.

Q – Can I install my Tastic directly above a shower recess?

A – For safety reasons it is not recommended to install above shower recess. Please refer to the current Australian/New Zealand Wiring Rules AS/NZS 3000 relating to damp situations for further details.

Q – Can I replace by 275 watt heat lamps with 375 watt lamps?

A – You can only use heat lamps which have been fitted and approved for use in your product. The rating label will state the maximum wattage for your product.

Q – What is the maximum recommended light globe wattage that I can install in my Tastic?

A – Check the rating label for the maximum safe wattage for your product.

Q – What will happen if I leave my heat lamps on without fan operation?

A – On certain models (Eco & Easy Duct) the fan will commence operation automatically to keep the unit operating at a safe temperature. When the unit has cooled sufficiently the fan will switch off automatically. While the heat lamps of Classic Tastic models will operate normally when the fan is off.

Q – Why is my Tastic making noise?

A – All Tastics create some noise due to the rapid movement of air through the Tastic.

Q – Can I retro fit a remote control to my existing hardwired Tastic?

A – No, unfortunately this is not possible.

Q – My Tastic unit's extraction fan doesn't seem to be removing all the moisture and steam from my bathroom?

A – There are a number of factors that will influence the exhaust fan's performance. Firstly you can improve your cross ventilation via an open door or window; refer to page 6 of the instructions for details on improving the room's air flow.

If you live in a traditionally cooler climate, in the winter months during hot showers, you may notice that there is more moisture and condensation build up. If this is the case, you may wish to improve your natural ventilation or invest in an additional exhaust fan.

Bathrooms which have high ceilings, are larger than average, or have an open shower may all require additional ventilation. We recommend that you visit our www.ixlappliances.com.au for further details and suggestions on effectively ventilating your bathroom.

Q – Can the installer rotate the IXL wall switch mechanisms?

A – Yes, the wall switches can be rotated by a qualified electrical trades person.

Q – Can my installer use an alternative wall switch mechanism other than the one supplied with my IXL product?

A – Yes, your authorised installer can use an alternative switch mechanism.

For more information or help, please contact IXL Home on 1300 727 421.

This Warranty against defects for your newly purchased Tastic product is proudly prepared by IXL Home Pty Ltd of 1K Marine Parade, Abbotsford, VIC 3067, phone 1300 727 421.

1. IXL Home Tastic products come with guarantees that do not exclude the following consumer entitlements under the Australian Consumer Law:
 - a. replacement or refund for a major failure and compensation for any other reasonably foreseeable loss or damage; and
 - b. to have the goods repaired or replaced if goods fail to be of acceptable quality and the failure does not amount to a major failure.
2. IXL Home warrants that your product and related supply will be free from defects in materials and workmanship during the warranty term. Your in home warranty term is five years with a two year heat lamp and inline motor replacement warranty, commencing from the date of purchase. IXL Home acknowledges this product requires professional installation and product removal is hazardous to consumers, accordingly any necessary inspections and services will be carried out on site. You should not attempt de-installation.
3. Subject to Point 1, IXL Home will repair any defects in materials and workmanship during the warranty term and if the product is deemed irreparable provide a replacement of an equivalent current model where the balance of the warranty period from the original date of purchase will take effect.
4. To the fullest extent permitted by law and subject always to Point 1, IXL Home will not be liable for:
 - a. any loss or damage arising from loss of use, loss of profits or revenue; or
 - b. for any indirect or consequential loss or damage resulting from any breach of this warranty against defects.
5. Defective IXL Home Tastic products may be repaired using refurbished parts or if required, completely replaced by a refurbished product of the same type.

Limitations to Your IXL Home Warranty

6. Subject to Point 1, this Warranty:
 - a. will only be provided to the original purchaser where the original purchase was made from a IXL Home Authorised Dealer or Reseller and proof of such purchase can be presented at the time of service;
 - b. only applies to IXL Home Tastic products purchased in Australia from a IXL Home Authorised Dealer or Reseller and installed by a qualified person where a Certificate of Compliance in accordance with State/Territory laws is provided;
 - c. will not apply where the defect in or failure of the product is attributable to misuse, abuse, accident or non-observation of the manufacturer's instructions. This product must be used in accordance with the manufacturer's instructions;
 - d. will not cover faults due to normal wear and tear with reasonable use nor consumable components such as globes, filters, glass items, etc;

- e. will not cover any damages or problems caused to this product by natural forces, e.g. storm, fire, flood, and earthquake; or by intrusion or accumulation (or both) of foreign matters, e.g. dust, soil, and moisture. IXL Home recommends that you take out appropriate insurances to protect your product to this end;
- f. will not apply if this product is installed in a mobile dwelling eg. caravan or boat;
- g. will not apply if this product is removed from the location where it was first installed;
- h. is immediately void if the serial or model number label is removed or defaced;
- i. is immediately void if the product is serviced or repaired by an unauthorised/unqualified personnel;
- j. covers use of this product for domestic use only;
- k. will not be restarted or extended upon repair or replacement of the product or a part.

How to make a Claim under Your IXL Warranty

7. To make a claim under this Warranty you will need to:
 - a. contact IXL Home service department on 1300 727 421 or service@ixl.com.au for Australia, 0800 727 421 or service@ixlappliances.co.nz for New Zealand to provide details and register your claim enabling a IXL Home assessment;
 - b. submit proof of purchase with your claim eg. tax invoice or purchase receipt;
 - c. where a property has been constructed by a builder/developer and it is fitted with IXL products, please submit proof of purchase by way of the certificate of occupancy, with your claim.
8. IXL Home will contact you to make arrangements for service on site.
9. Subject to Point 1, you will be responsible for any costs relating to the provision of your product to a IXL Home Authorised Service Dealer.
10. Subject to Point 1, in the event you live more than 50 km from a IXL Home Authorised Service Dealer you may be subject to travel or transport costs to facilitate the repairing or replacement of your IXL product.
11. IXL Home and its Authorised Service Dealers reserve the right to seek reimbursement of any costs incurred by them should your IXL product be found to be in good working order.

Privacy

The privacy of your personal information has always been important to us. To learn more about how we collect, keep and use your personal information, please obtain a copy of our privacy statement by visiting our website at www.ixlappliances.com.au or by contacting us via email on info@ixl.com.au or by telephone on 1300 727 421.



Visit the IXL Home website below to register your warranty details online.

Australia

www.ixlappliances.com.au/warranty

New Zealand

www.ixlappliances.com.au/warranty

For comments, questions or warranty matters:

IXL Home Pty Ltd

Australia:

1K Marine Parade,
Abbotsford VIC 3067, Australia
Free Call: 1300 727 421
service@ixl.com.au
www.ixlappliances.com.au

New Zealand:

Free Call: 0800 727 421
service@ixl.com.au
www.ixlappliances.co.nz

© Copyright IXL Home, 2020



Approved by the appropriate electrical supply authorities.