

i

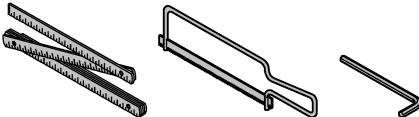

*19 332

32mm





1

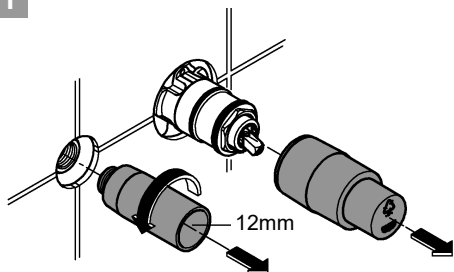

2

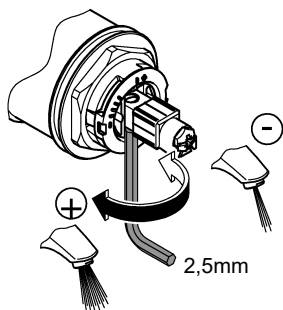

3

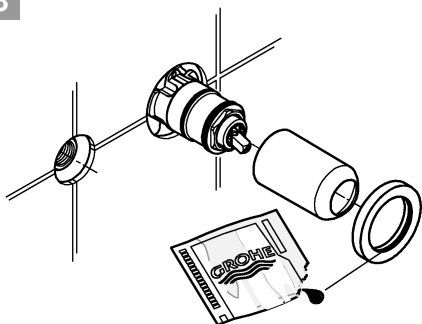

4

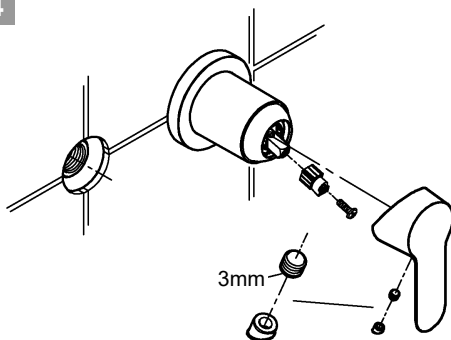

5

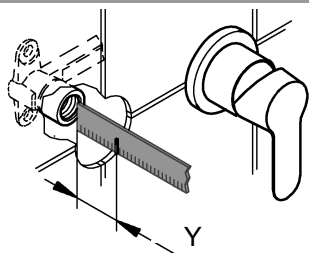

6

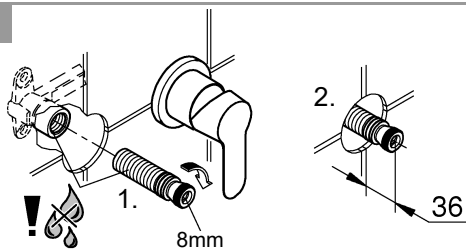

7

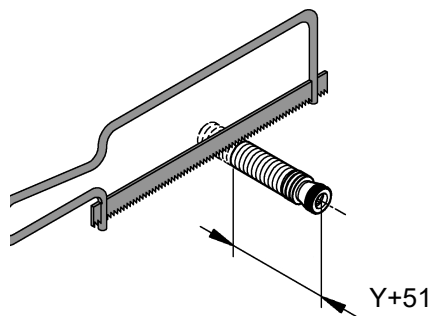

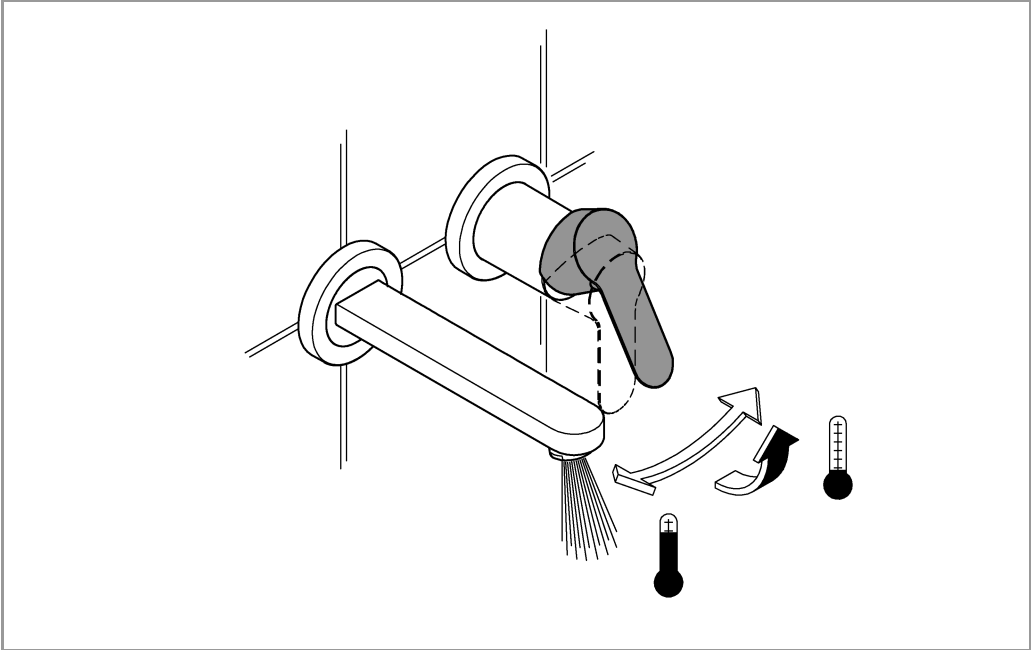

Y+51

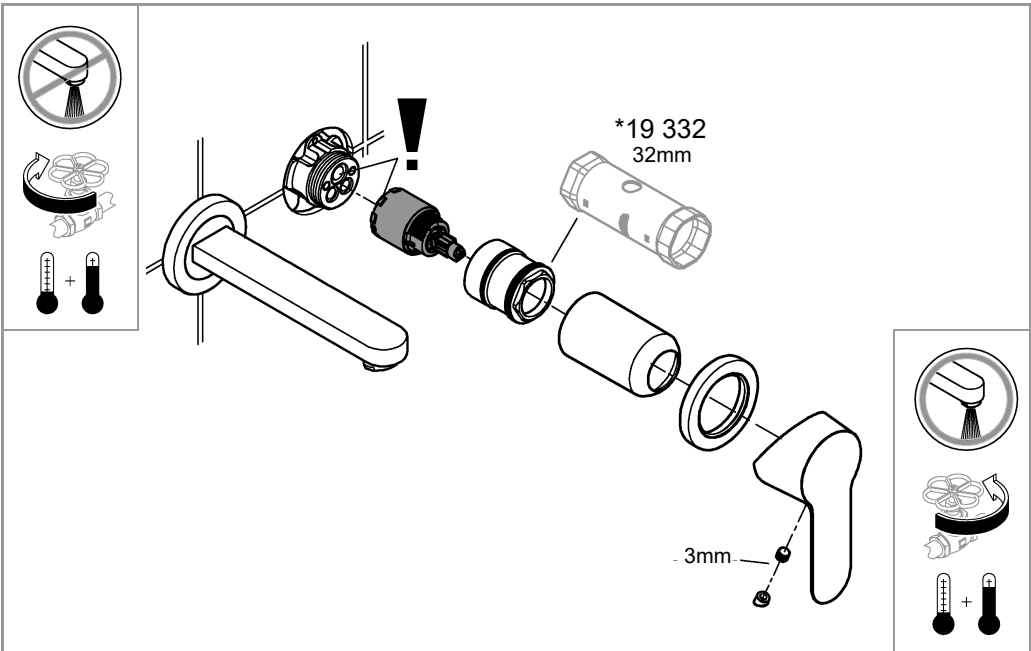

MAINTENANCE 





*19 332	32mm
	

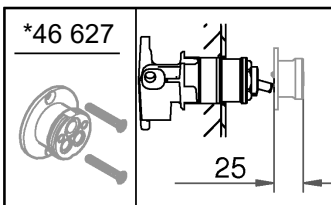
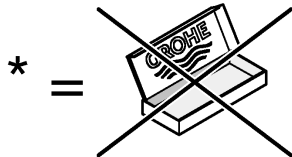
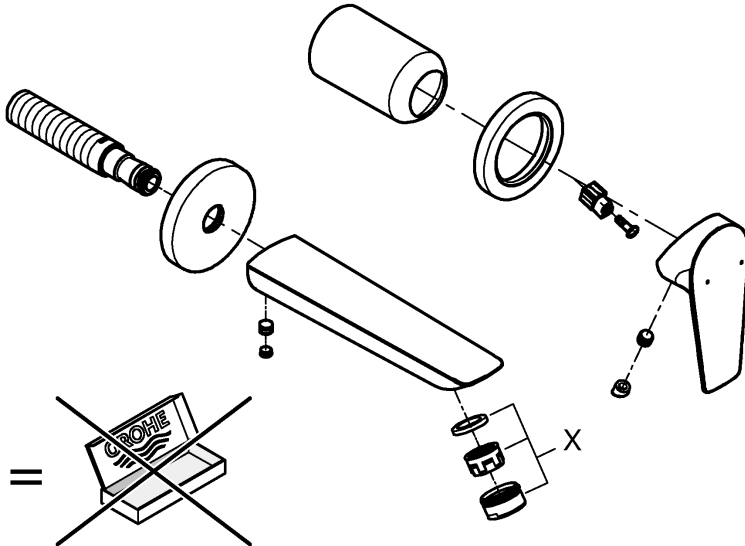
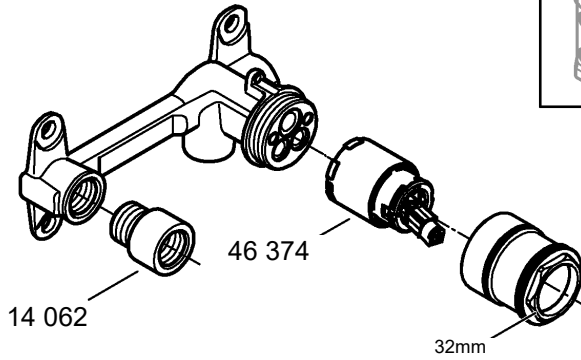

	X
4,5 l/min	48 280
25 l/min	13 961

Application

- 29 219: for basin
- 29 220: for bath

Can be used in conjunction with:

- Pressurised storage heaters
- Thermally controlled instantaneous heaters
- Hydraulically controlled instantaneous heaters

Operation with unpressurised storage heaters (open water heaters) is **not** possible.

Specifications:

- Flow pressure min. 50 kPa - recommended 100 - 500 kPa
- Operating pressure max. 1000 kPa
- Test pressure 1600 kPa

If static pressure is greater than 500 kPa, fit pressure reducer.
Avoid major pressure differences between hot and cold water supply.

- Flow rate at 300 kPa flow pressure approx. 4,5 L/min
- 29 219: approx. 25 L/min
- 29 220:
- Temperature (maximum) 70 °C
- Hot water inlet: (energy saving) 60 °C
- Recommended:
- Thermal disinfection possible



Installation

Flush piping system prior and after installation of fitting thoroughly (Consider EN 806)!

This product must be installed in conformance with local codes e.g. AS/NZS 3500 series of standard!

Installation, see Fig. [1] - [7].

Refer to the dimensional drawing.

1. Determine dimension "Y" from upper edge of concealed mixer housing to the face of tiles.
2. Cut connection nipple to length so that the installation dimension is "Y" + 51mm.

Using a 12mm allen key, screw the connection nipple into the concealed housing so that the installation dimension is 8mm. Tighten spout from below using a 2.5mm allen key.

Open cold and hot-water supply and check connections for watertightness!



Check fitting for correct operation.



Flow rate limiter.

This mixer is fitted with a flow rate limiter, permitting an infinitely individual variable reduction in the flow rate. The highest possible flow rate is set by the factory before despatch.

The use of flow rate limiters in combination with hydraulic instantaneous water heaters is not recommended.



Maintenance

Inspect and clean all parts, replace as necessary and grease with special grease.

Shut off cold and hot water supply!

Replacing the cartridge.

Assemble in reverse order.

Observe the correct installation position!

Make sure that the cartridge seals engage in the grooves on the housing. Screw in and tighten screwing.



Replacement parts (* = special accessories).

Care

For directions on the care of this fitting, refer to the accompanying Care Instructions.

AUS

Reece Australia Pty Ltd
118 Burwood Hwy
Burwood VIC 3125

Tel.: +61 3 9274 0000
Email: admin@reece.com.au



NZ

Robertson
25 Vestey Drive
Mt Wellington, Auckland

Tel.: +64 9 5730490
Email: sales@robertson.co.nz